

Xenocs' collimator, developed in close cooperation with Institut de Biologie Moléculaire et Cellulaire (IBMC - Strasbourg), makes life more simple for crystallographers. Our collimation system is based on two fluorescent screens. Indeed after source maintenance or pinhole reconfiguration, alignment can be easily found and flux optimized with a pindiode detector (10 minutes procedure).

The compact mechanical system does not require costly gas shielding or heavy gas bottle transportation as it works under dynamic primary vacuum. With its adjustable length, the collimator maintains the beam under vacuum to very close to the crystal. This optimum condition improves your data quality by avoiding air absorption and diffusion.

The beamstop can be removed allowing an easy crystal installation on the goniometer and remounted without losing the original position.

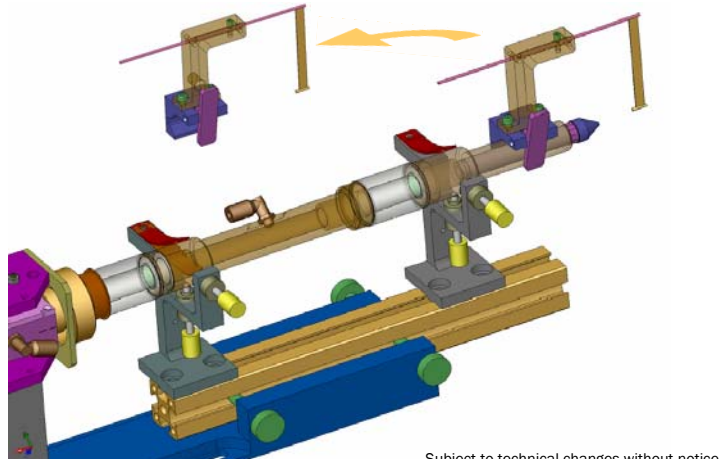
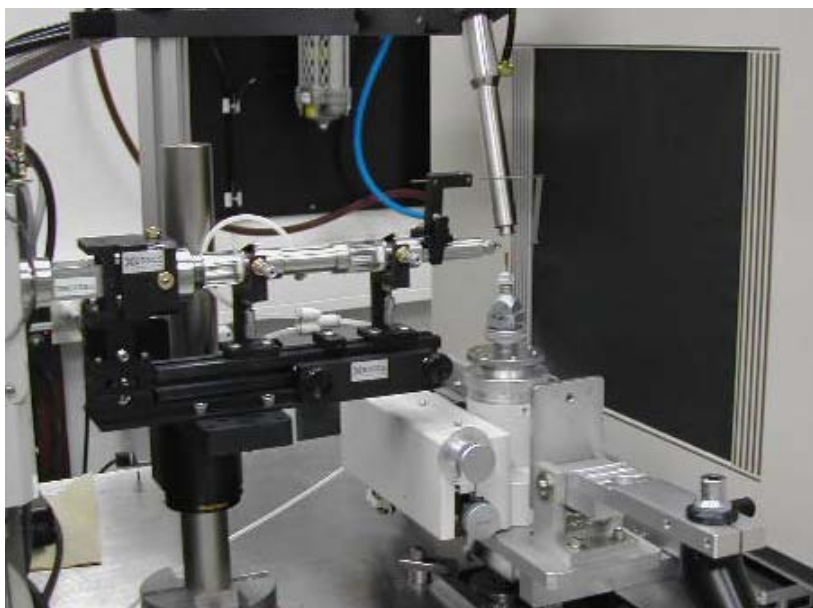

Subject to technical changes without notice

### Main features

Allows FOX2D optics installation every diffractometer on the market:

- two fluorescent screens for Cu and Mo radiations
- two pinhole systems (output pinhole interchangeable)
- removable beamstop for crystal positioning
- adjustable length to limit air diffusion
- operation under dynamic vacuum
- optional security shutter
- 10 min alignment procedure



DMC-050105-collimator system-TDS-02

#### Features

■ beamstop:	Ø 1.6 mm standard (or 2 mm)
■ entry pinhole:	Ø 1 mm standard (1.25 mm optional)
■ exit pinhole:	Ø 0.3 mm standard (0.2 mm or 0.5 mm optional)
■ fluorescent screens:	for Cu or Mo radiations

#### Mechanical dimensions

■ overall dimensions	130 mm (h) x 90 mm (w)
■ system length	range between 190 and 330 mm
■ XYZ adjustment table	14x14x5 mm <sup>3</sup> stroke
■ weight	2.2 kg

#### Vacuum features

■ primary vacuum housing	improved data quality
■ Kapton® windows	loss per window : 0.75% (Kapton® foil)
■ dry vacuum pump	working pressure : 1mbar pumping speed : 0.6 m <sup>3</sup> /h voltage : 220V or 110V