

# Accessories for SAXS Hybrid Scatterless Slits

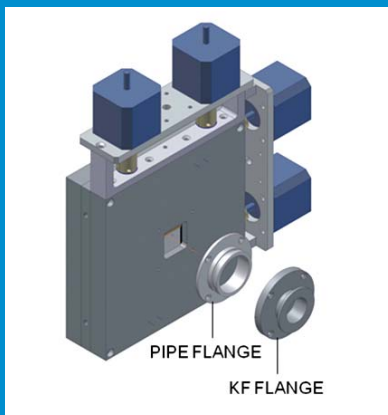

Fig.1 : Complete slit set up with 4 individually movable blades

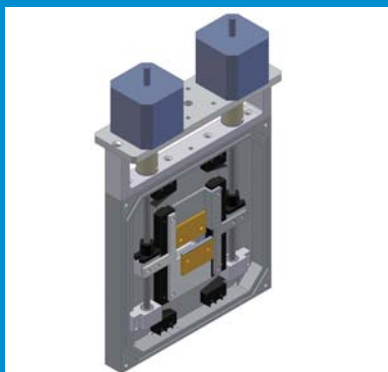

Fig.2 : Detailed view of the two motorized vertical blades

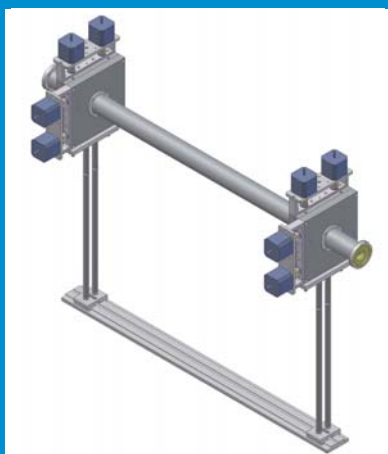

Fig. 3 : Two slits collimator system

One of the most difficult problems to solve in a SAXS system is to suppress the parasitic noise induced by the collimation slits. Xenocs scatterless slits practically eliminate parasitic slit scattering, leading to enhanced resolution and flux.

A simple hybrid (single crystal edge + metal base) blade design leads to a much simplified SAXS design, in which generally two – in many cases only one – sets of slits are needed for high resolution SAXS. These slits have been proven to work even at synchrotron flux levels and have been tested at ESRF and on more traditional lab SAXS setups.

Scatterless slits, which are composed of 4 individually movable blades, are available for both Molybdenum and Copper radiation in manual or motorized configuration. Motorization consists in the addition of 4 motors, 4 motor drivers and communication module. Slits are easily remote controllable from a PC with a single RS232 or RS422 cable which can control up to 3 sets of slits (12 motors).

Configuration guide hereunder describes the existing solution. For specific requests, upgrades of your own system or extension to other energy ranges, do not hesitate to contact us.

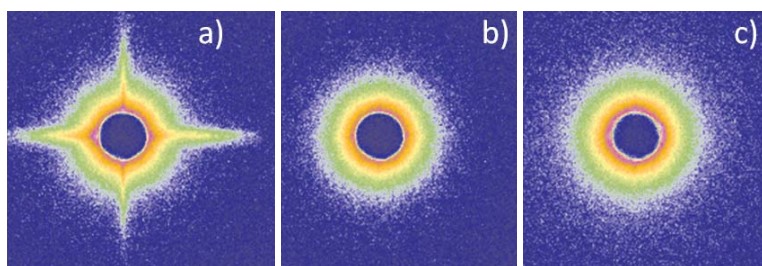

Fig. 3: Images of empty SAXS camera of the D2AM beamline at ESRF, France, collected on a 1.67m SAXS camera and 3mm beamstop, energy set to 17.48keV.

(a) Standard collimation, flux maximized to  $3.4 \times 10^{10}$  ph/s @17.48keV on sample

(b) Same collimation, last anti scatter slits replaced by Xenocs' scatterless slits, same flux

(c) Collimation scheme simplified including Xenocs' scatterless slits allows to increase the flux up to  $9.6 \times 10^{10}$  ph/s with same beam focus on detector.

## Ordering Guide

### Motorized

Item	Designation
• ACM-C8-1SL01-A	Motorized vacuum compatible slits for Cu radiation
• ACM-C8-2SL01-A	Motorized two-slit SAXS collimator vacuum compatible for Cu radiation
• ACM-M8-1SL01-A	Motorized vacuum compatible slits for Mo radiation
• ACM-M8-2SL01-A	Motorized two-slit SAXS collimator vacuum compatible for Mo radiation

### Manual

Item	Designation
• ACM-C8-1SL02-A	Manual driven vacuum compatible slits for Cu radiation
• ACM-M8-1SL01-A	Manual driven vacuum compatible slits for Mo radiation

## Technical Specifications

Subject to technical changes without notice

• Slit set up	4 individually movable blades
• Vacuum	Not tested below to $10^{-4}$ mbar
• Opening	Maximum of 20 mm Each blade can move independently from -10mm - +10mm
• Resolution	Standard drive screw 0.5mm per revolution with microstepping motors providing a total of 102400 steps/mm
• Accuracy	3 $\mu$ m (standard slides) 1 $\mu$ m (high precision slides)
• Remote control	Integrated controller Motors are directly recognized by SPEC in Party mode All motors can be connected on a single serial port of the PC
• External Power Supply	12-48 V DC has to be supplied

19 Rue François Blumet  
38360 Sassenage - France

Phone: +33 4 76 26 95 40

Fax: +33 4 76 26 95 49

[www.xenocs.com](http://www.xenocs.com)

[sales@xenocs.com](mailto:sales@xenocs.com)